

CDCTL01A Datasheet

1 Description

CDCTL01A is an SPI interface UART controller, with the UART port hardcoded to use the CDBUS protocol. (Or simply an SPI interface CDBUS controller.)

CDBUS is a simple protocol designed for serial ports and serial bus communication, commonly employed in RS-485 buses. It utilizes hardware arbitration and other mechanisms to avoid data conflicts, allowing nodes to freely transmit and receive data packets, thereby overcoming the limitations of single-master polling.

2 Features

- In addition to RS-485 communication, this chip also supports M-LVDS, single-wire UART communication, UART expansion, and more.
- Supports multi-master communication, peer-to-peer communication, multicast communication, etc.
- Supports multiple modes such as dual-rate arbitration mode, single-rate high-speed peer-to-peer mode, traditional mode, and full-duplex mode.
- 50Mbps maximum UART baud rate.
- 50MHz maximum SPI clock.
- 8 packet buffers for receive, 2 packet buffers for transmit. (Each buffer is 256 bytes.)
- Small package: QFN16 3x3mm.
- 3.3V ($\pm 10\%$) single power supply.
- Operating temperature range: $-40 \sim 125$ °C.
- Crystal oscillator or external clock input.
- 4-wire or 3-wire SPI (SDO and SDI tied together).
- 5V tolerant RI input.
- Ultra-wide system clock range: 32KHz \sim 150MHz.
- Lead(Pb)-free / RoHS-compliant.

3 Applications

- Industrial Automation
- Robotics
- Automotive
- Smart City
- Consumer Electronics
- IoT

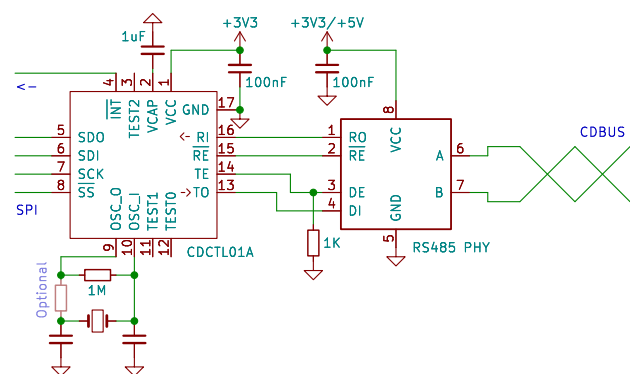

Reference Schematic

(For a crystal, the 1M Ω resistor is required; the series resistor (~ 240 Ω) is optional for amplitude adjustment.)

4 CDBUS Protocol

CDBUS has a 3-byte header: [src_addr, dst_addr, data_len], followed by user data, and concluding with a 2-byte CRC (identical to MODBUS CRC).

The CDBUS protocol at the byte level can be directly used for traditional serial communication, such as traditional UART, RS-232, RS-485, and USB virtual serial ports.

The full CDBUS protocol at the bit level requires dedicated hardware controllers (or software emulation) to achieve conflict avoidance, higher speeds, and strong real-time performance.

4.1 Arbitration Mode (CDBUS-A)

- It introduces an arbitration mechanism, similar to the CAN bus, to automatically avoid conflicts.
- Supporting dual baud rates achieves high-speed communication, with the maximum baud rate during the high-speed phase up to: $\text{sysclk} \div 3$. (e.g. 50 Mbps for 150 MHz sysclk.)
- Supports unicast, multicast and broadcast.
- The maximum user data size is 253 bytes.
- Hardware packing, unpacking, verification and filtering, saving your time and CPU usage.
- Compatible with traditional RS-485 hardware (arbitration function remains effective).

The protocol timing example, consisting of only one byte of user data:
(You can configure the lengths of idle time and transmission permit time.)

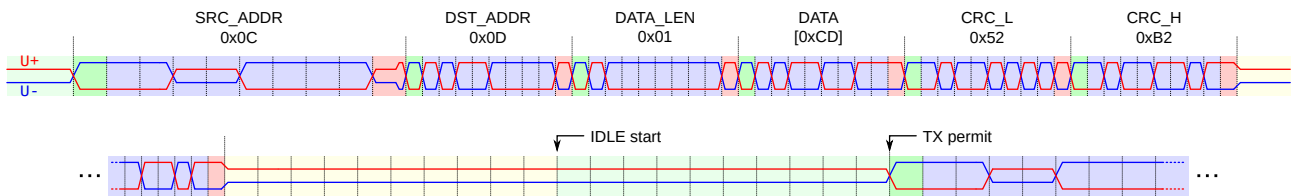

Tips:

- When a high-priority node needs to send unimportant data, we can dynamically increase the transmission permit time (TX_PERMIT_LEN).

Arbitration example:

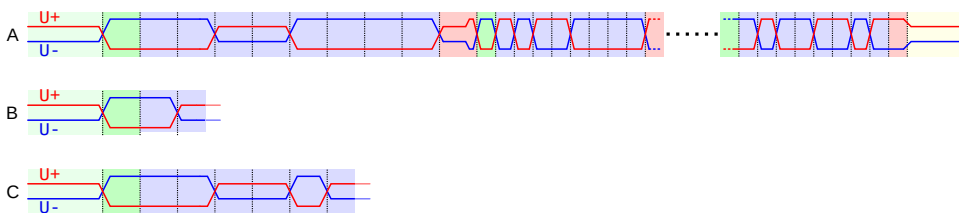

Example waveforms for TO and TE pins:

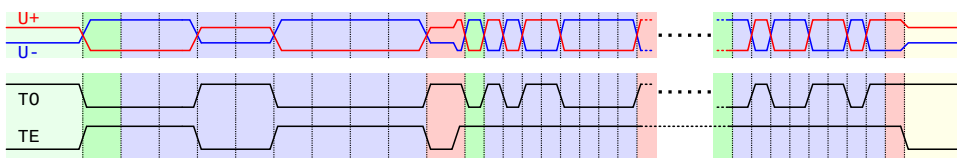

The RX data sampling point for reception is at 1/2 bit; for TX readback, it's at 3/4 bit.

Lower-priority nodes back off during arbitration and retransmit after the bus is idle, until successful or cancelled by the user.

4.2 Break Sync Mode (CDBUS-BS)

In CDBUS-A mode, if the low-speed portion takes longer, it can become a bottleneck for communication efficiency. To address this, single-rate peer-to-peer bus communication can be achieved using CDBUS-BS mode:

- Different nodes have different configurations for the TX_PERMIT_LEN parameter, requiring sufficiently large differences to avoid conflicts.
- If any node has pending data frames waiting to be sent before the transmission permit point, transmission starts from that point.
- Otherwise, wait until the idle time exceeds MAX_IDLE_LEN. When there are pending data frames waiting for transmission, first send a break character to bring the bus out of the idle state.

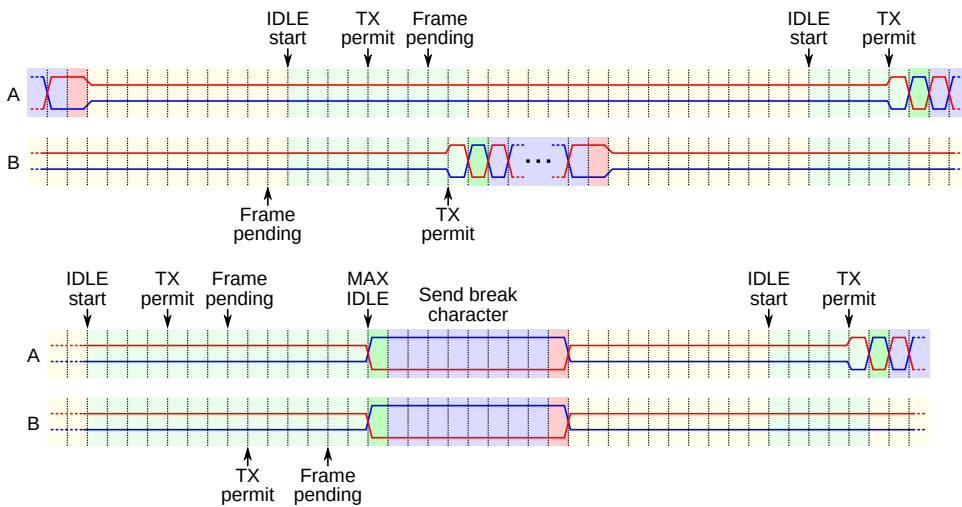

The CDBUS-BS mode is suitable for high-speed applications with few nodes, and it is also suitable for software implementation.

5 CDBUS IP Core

Chip source code and details: <https://cdbus.org>

5.1 Block Diagram

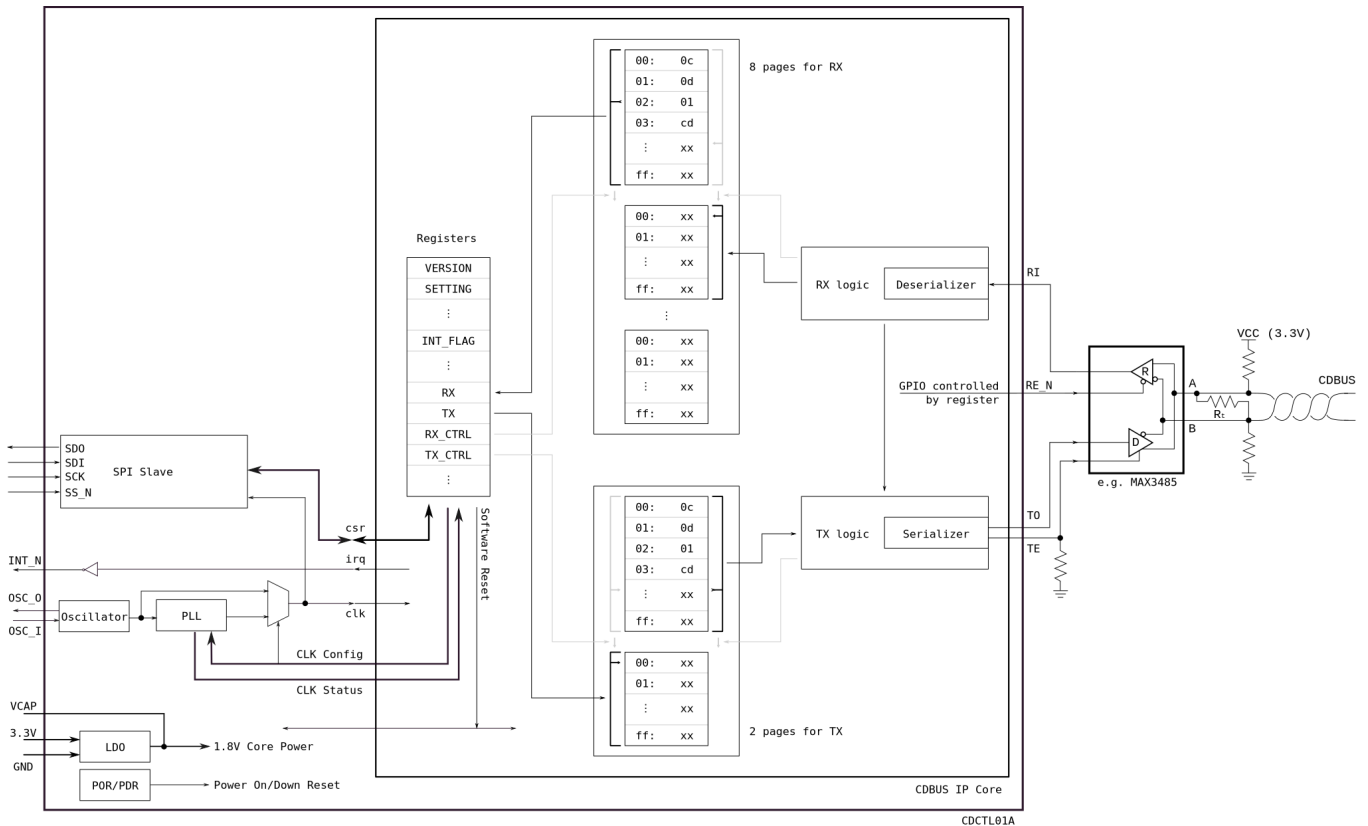

6 Pin Definition

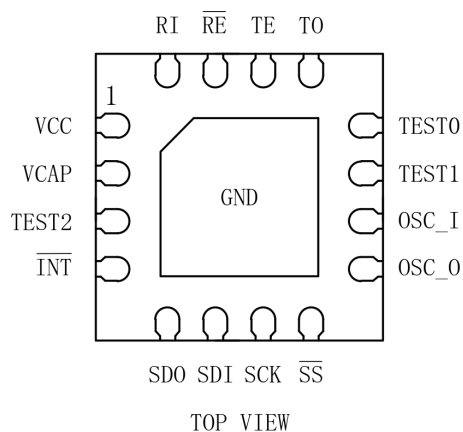

No	Name	I/O	Internal Pull	Description
17	GND			Ground
1	VCC			Supply voltage, 3.3V ($\pm 10\%$); 100nF bypass cap to ground
2	VCAP			Internal 1.8V ($\pm 10\%$) 100mA LDO output; 1uF bypass cap to ground
3, 11, 12	TESTx	I	Down	Leave empty or tie to ground

4	INT	O	Up	Interrupt; open-drain (default) or push-pull output
5	SDO	O	-	SPI MISO
6	SDI	I	-	SPI MOSI
7	SCK	I	-	SPI clock
8	SS	I	-	SPI chip select
9	OSC_O	O	-	OSC output (leave empty if external clock used)
10	OSC_I	I	-	OSC input or external clock input
13	TO	O	-	TX output; to RS-485 PHY transmit pin
14	TE	O	-	TX enable; to RS-485 PHY transmit-enable pin
15	RE	O	-	GPIO push-pull output; usually drives RS-485 PHY receive-enable pin
16	RI	I	-	RX input; to RS-485 PHY receive pin (5V tolerant)

7 Specifications

7.1 Mechanical Specifications

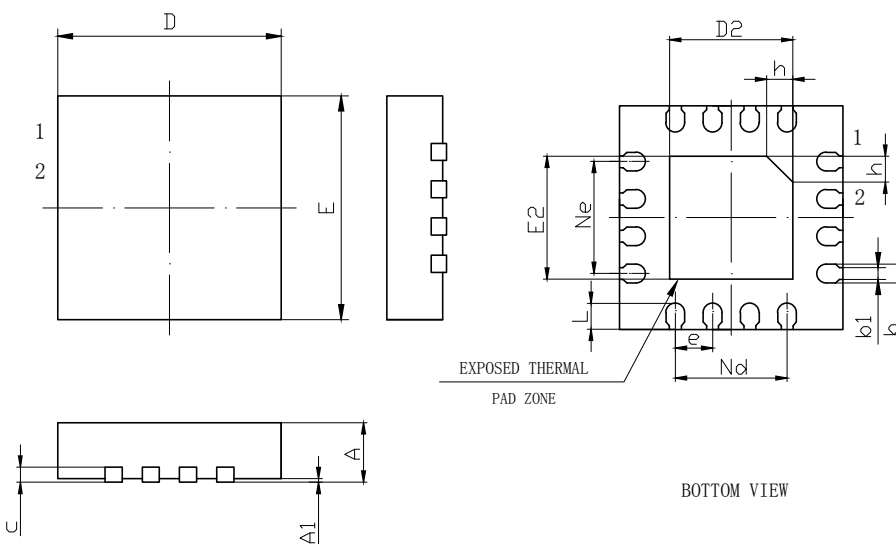

SYMBOL	MILLIMETER		
	MIN	NOM	MAX
A	0.80	0.85	0.90
A1	—	0.02	0.05
b	0.18	0.25	0.30
b1	0.11	0.16	0.21
c	0.10	0.15	0.20
D	2.90	3.00	3.10
D2	1.55	1.65	1.75
e	0.50BSC		
Ne	1.50BSC		
Nd	1.50BSC		
E	2.90	3.00	3.10
E2	1.55	1.65	1.75
L	0.30	0.35	0.40
h	0.30	0.35	0.40

7.2 Absolute Maximum Ratings

Parameter	Min.	Max.
Storage Temperature (Ambient)	-55 °C	150 °C
Electrostatic Discharge Human Body Model (ESD-HBM) ¹	-	±2000 V
Electrostatic Discharge Charged Device Model (ESD-CDM) ²	-	±750 V
High Temperature Latch-Up ³	-	±200 mA / +1.5 VccMax

1. Refer to AEC-Q100-002. Zap 1 pulse with 0.3 sec interval.
2. Refer to AEC-Q100-011.
3. Refer to JESD78F:2022, Ta=+125°C.

7.3 Operating Conditions

Parameter	Min.	Max.
Operation Temperature	-40 °C	125 °C

7.4 DC Electrical Characteristics

Parameter	Min.	Typ.	Max.
Supply Voltage VCC	-10%	3.3 V	+10%
V _{IL}	-0.3 V	-	0.8 V
V _{IH}	2.0 V	-	3.6 V
V _{IH} (RI pin only)	2.0 V	-	5.5 V
V _{OL}	-	-	0.4 V
V _{OH}	2.4 V	-	-
I _{OL} , I _{OH}	-	12 mA	-
I _{OL} , I _{OH} (OSC_O pin only)	-	2 mA	-
Input or I/O Leakage	-	-	+/-10 uA
I _{VCC} (F _{sys} = 32KHz)	-	140 uA	-
I _{VCC} (F _{sys} = 12MHz, pll off)	-	2.8 mA	-
I _{VCC} (F _{sys} = 12MHz, pll on)	-	8.7 mA	-
I _{VCC} (F _{sys} = 60MHz)	-	10.6 mA	-
I _{VCC} (F _{sys} = 150MHz)	-	14.3 mA	-

7.5 Timing Specifications

Symbol	Parameter	Min.	Max.
F _{CRYSTAL}	Crystal frequency	4 MHz	32 MHz
F _{EXT}	External clock input	32 KHz	32 MHz
F _{SYS}	System clock frequency	32 KHz	150 MHz
F _{SCK}	SPI clock frequency	-	50 MHz
F _{UART}	Baud rate	-	50 Mbps

Additional restrictions on RX and TX register reads and writes: $F_{SCK} \leq F_{SYS} \times 80\%$

Writing to any register requires: $t_{CSH} \geq \frac{1}{F_{SYS} \times 80\%}$

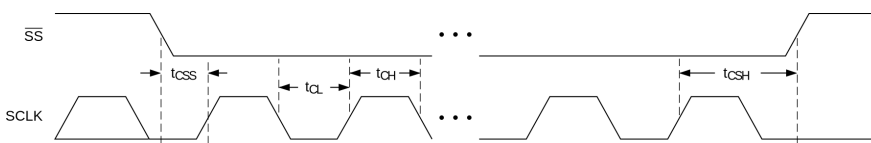

8 Register Reference

Register Name	Addr	Access	Default	Description (8-bit width by default if not specified)
VERSION	0x00	RD	0x10	Hardware version
CLK_CTRL	0x01	RD/WR	0x00	Clock Control
SETTING	0x02	RD/WR	0x10	Configuration
IDLE_WAIT_LEN	0x04	RD/WR	0x0a	Idle entry wait time
TX_PERMIT_LEN_L	0x05	RD/WR	0x14	TX permit wait time (10 bits)
TX_PERMIT_LEN_H	0x06	RD/WR	0x00	
MAX_IDLE_LEN_L	0x07	RD/WR	0xc8	Max idle wait time, BS mode (10 bits)
MAX_IDLE_LEN_H	0x08	RD/WR	0x00	

TX_PRE_LEN	0x09	RD/WR	0x01	TE pre-assert time (2 bits)
FILTER	0x0b	RD/WR	0xff	Local address
DIV_LS_L	0x0c	RD/WR	0x67	Low-speed rate setting (16 bits)
DIV_LS_H	0x0d	RD/WR	0x00	
DIV_HS_L	0x0e	RD/WR	0x67	High-speed rate setting (16 bits)
DIV_HS_H	0x0f	RD/WR	0x00	
INT_FLAG	0x10	RD	n/a	Status
INT_MASK	0x11	RD/WR	0x00	Interrupt mask
RX	0x14	RD	n/a	Read RX page
TX	0x15	WR	n/a	Write TX page
RX_CTRL	0x16	WR	n/a	RX control
TX_CTRL	0x17	WR	n/a	TX control
RX_ADDR	0x18	RD/WR	0x00	RX page read pointer (rarely used)
RX_PAGE_FLAG	0x19	RD	n/a	RX page flag
FILTER_M0	0x1a	RD/WR	0xff	Multicast filter0
FILTER_M1	0x1b	RD/WR	0xff	Multicast filter1
PLL_ML	0x30	RD/WR	0x12	PLL M[7:0] (M: 9 bits)
PLL_OD_MH	0x31	RD/WR	0x20	PLL OD and M[8]
PLL_N	0x32	RD/WR	0x00	PLL N (5 bits)
PLL_CTRL	0x33	RD/WR	0x01	PLL Control
PIN_INT_CTRL	0x34	RD/WR	0x00	$\overline{\text{INT}}$ pin Control
PIN_RE_CTRL	0x35	RD/WR	0x00	$\overline{\text{RE}}$ pin Control
CLK_STATUS	0x36	RD	0x01	Clock status

Time unit: one bit period at the low-speed baud rate.

8.1 CLK_CTRL:

FIELD	DESCRIPTION
[7]	Soft reset: write 1 to reset device
[0]	Clock select: 0: OSC input, 1: PLL output

8.2 SETTING:

FIELD	DESCRIPTION
[6]	Full duplex mode
[5]	Break Sync mode
[4]	Enable arbitration
[3]	Save broken frame
[2]	CRC maintained by user
[1]	Invert TO pin output
[0]	Enable push-pull output for TO and TE pin

The TO pin defaults to an open-drain output and the TE pin defaults to a high-resistance output.

[6]	[5]	[4]	DESCRIPTION
0	0	0	Traditional half-duplex mode
0	0	1	CDBUS-A mode (default)
0	1	0	CDBUS-BS mode
1	0	0	Full-duplex mode

8.3 TX_PRE_LEN:

Example waveforms for TO and TE pins (TX_PRE_LEN = 1 bit):

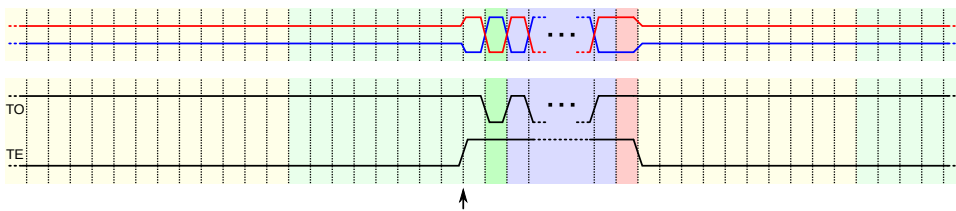

Unused for Arbitration mode and the break character automatically generated by BS mode.

8.4 FILTERS:

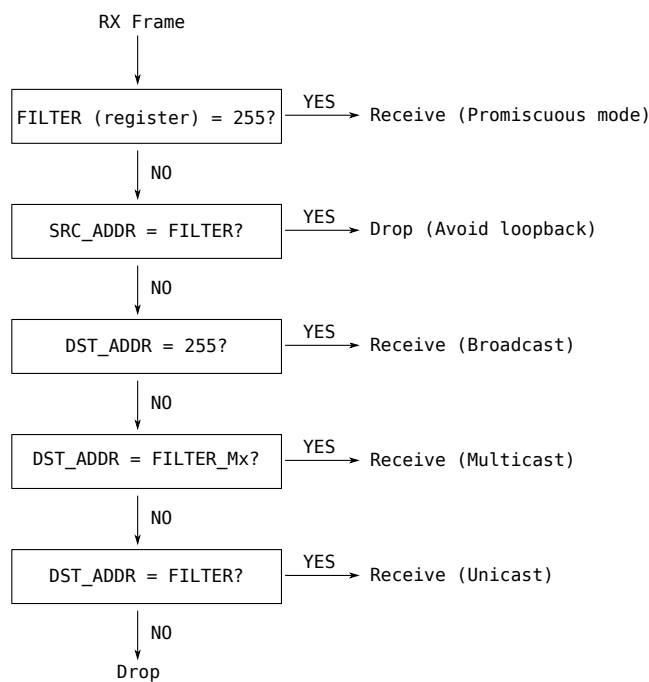

The default value of FILTER_Mx (0xff) indicates it is disabled. Any address other than 0xff can be used as a multicast address.

8.5 DIV_xx_x:

Baud rate divider value:

$$div_xx[15 : 0] = \frac{sysclk}{baudrate} - 1$$

The minimum value is 2.

For single rate, DIV_HS needs to be set to the same value as DIV_LS.

8.6 INT_FLAG:

FIELD	DESCRIPTION
-------	-------------

[7]	1: TX error (TX low, RX sampled high)
[6]	1: TX collision detected
[5]	1: TX page released by hardware
[4]	1: RX error (frame broken)
[3]	1: RX lost (no empty RX page)
[2]	1: Break character received
[1]	1: RX page ready to read
[0]	1: Bus idle

Reading this register will automatically clear bit7, bit6, bit4, bit3 and bit2.

8.7 INT_MASK:

```
irq = ((INT_FLAG & INT_MASK) != 0)
int_n = !irq
```

8.8 RX_CTRL:

FIELD	DESCRIPTION
[4]	Reset RX block
[1]	Switch RX page
[0]	Reset RX page read pointer

8.9 TX_CTRL:

FIELD	DESCRIPTION
[5]	Send break character
[4]	Abort TX
[1]	Switch TX page
[0]	Reset TX page write pointer

8.10 RX_PAGE_FLAG:

A value of zero indicates that the frame in the current RX page is correct;
 Non-zero indicates the pointer to the last received byte of the disrupted frame, including CRC.
 Always zero if 'save broken frame' is not enabled.

8.11 PLL_OD_MH:

FIELD	DESCRIPTION
[5:4]	PLL OD
[0]	PLL M[8]

8.12 PLL_CTRL:

FIELD	DESCRIPTION
[4]	PLL enable: 0: disable, 1: enable
[0]	PLL sleep: 1: sleep, 0: run

Reserved bits in this register must remain zero.

PLL output clock:

$$pll_output = \frac{osc_input}{pll_n + 2} \times (pll_m + 2) \times \frac{1}{2^{(pll_od[1]+pll_od[0])}}$$

When the OSC input is equal to 12MHz, the default PLL parameters correspond to an output of 60MHz.

The PLL parameters need to meet the following conditions:

$$1MHz \leq \frac{osc_input}{pll_n + 2} \leq 15MHz$$

$$100MHz \leq \frac{osc_input}{pll_n + 2} \times (pll_m + 2) \leq 500MHz$$

Switch to using the PLL clock:

- Change PLL N, M and OD values if needed
- Write 0x10 to PLL_CTRL
- Write 0x01 to CLK_CTRL

8.13 PIN_INT_CTRL:

FIELD	DESCRIPTION
[4]	Output mode: 0: open-drain, 1: push-pull

8.14 PIN_RE_CTRL:

FIELD	DESCRIPTION
[4]	Output mode: 0: disabled (high impedance), 1: push-pull
[0]	Output value: 0: low, 1: high

8.15 CLK_STATUS:

FIELD	DESCRIPTION
[2]	Clock switching status: 1: completed, 0: in progress
[1]	System clock is PLL output
[0]	System clock is OSC input

9 SPI Interface

Burst read and write are useful for accessing REG_RX and REG_TX.

Read or write depends on bit W/ \bar{R} :

- 0: Read
- 1: Write

FIELD	DESCRIPTION
-------	-------------

Ax	Register address
Wx	Write data
Rx	Read data
X	Don't care

Read or write single byte:

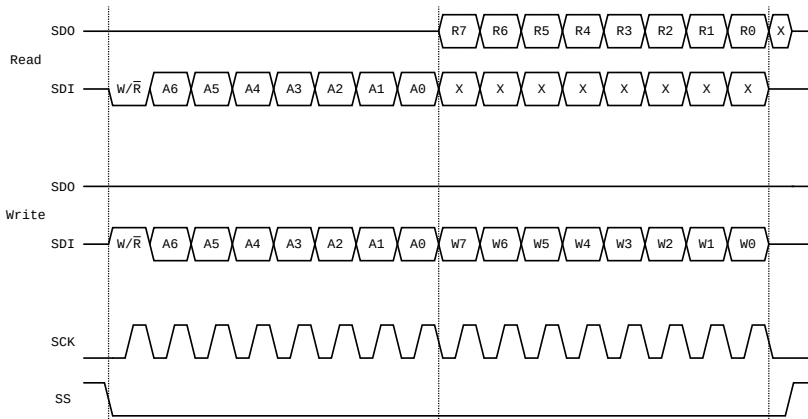

Burst read or write:

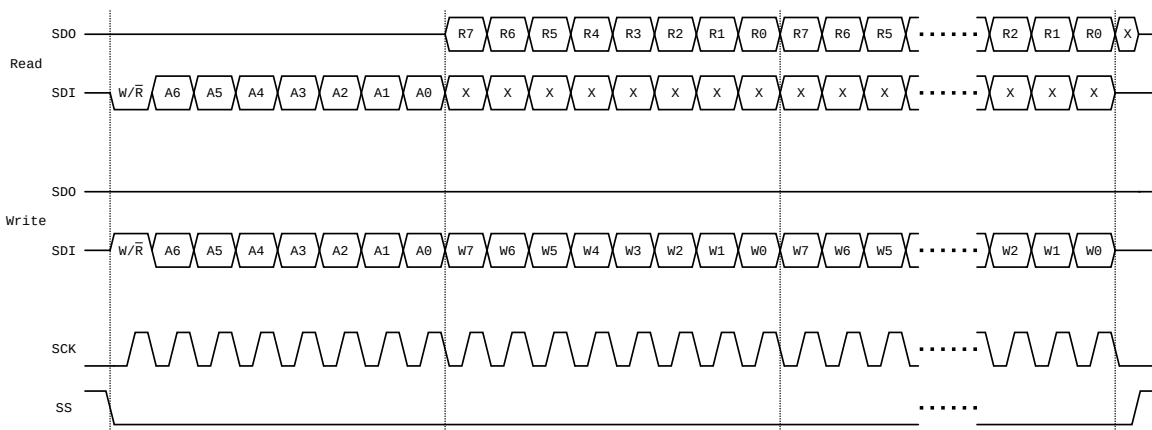

10 Operate Demonstration

10.1 Init

```

cd_write(REG_CLK_CTRL, 0x80);           // Soft reset
cd_write(REG_PIN_RE_CTRL, 0x10);       // Set RE_N pin to low
cd_write(REG_SETTING, 0x11);           // Enable push-pull output
cd_write(REG_FILTER, 0x0c);            // Set FILTER

// Set baudrates, LS and HS should be identical for single-rate
cd_write(REG_DIV_LS_L, 11);             // 1 Mbps @ 12MHz sysclk
cd_write(REG_DIV_LS_H, 0);
cd_write(REG_DIV_HS_L, 2);              // 4 Mbps @ 12MHz sysclk
cd_write(REG_DIV_HS_H, 0);

// Reset RX module to ignore errors received before baud rate is set (optional)

```

```
// cd_write(REG_RX_CTRL, 0x11);

// Enable interrupts (optional, MCU can also poll INT_FLAG periodically)
// cd_write(REG_INT_MASK, BIT_FLAG_TX_ERROR | BIT_FLAG_RX_ERROR \
    | BIT_FLAG_RX_LOST | BIT_FLAG_RX_PENDING);
```

Allow the chip to complete its startup after power-up. Wait 50ms or until the correct VERSION is read before initializing.

10.2 TX

```
uint8_t tx_buf[] = {
    0x0c, 0x0d, 0x02,           // src_addr, dst_addr, data_len
    0x01, 0x00                 // 2-byte example data, no CRC
};

cd_write_chunk(REG_TX, tx_buf, tx_buf[2] + 3); // Write CDBUS frame without CRC
while (!(cd_read(REG_INT_FLAG) & 0x20));      // Wait for prior TX frame to complete
cd_write(REG_TX_CTRL, 0x03);                  // Submit frame to start TX
```

The FILTER register is used only for receive filtering and does not affect transmission. For transmission, the sender should use its own address as the frame's src_addr; non-own addresses are typically used for loopback tests to bypass filtering.

10.3 RX

```
while (!(cd_read(REG_INT_FLAG) & 0x02));      // Wait for RX page ready
cd_read_chunk(REG_RX, rx_buf, 3);             // Read frame header
cd_read_chunk(REG_RX, rx_buf + 3, rx_buf[2]); // Read frame data
cd_write(REG_RX_CTRL, 0x03);                  // Release RX page
```

Reading the packet header and payload can also be done within a single \overline{SS} low period.

11 Copyright Statement

The CDBUS protocol is royalty-free for everyone except chip manufacturers.
Copyright (c) 2026 DUKELEC, All rights reserved.

12 Contact Information

- Sales and customer support: sales@dukelec.com
- Technical support: support@dukelec.com
- Business corporation: info@dukelec.com
- Website: <https://dukelec.com>

13 Change History

- 20260615 (v1.5): Add note on register time unit.
- 20260203 (v1.4): Clarified that packets deferred during arbitration will keep retrying.
- 20260123 (v1.3): Add filtering flowchart and sample code notes.
- 20240304 (v1.2): Modify the introduction description.
- 20231125 (v1.1): Add ESD and Latch-Up related data.
- 20230802 (v1.0): Init.